



# 3 Gun SA - Match 6

## Golden City

### 3 November 2012

Stage No.	STAGE	Type			Min No. Rds	Match Score Points	%														Metal			
		S	M	L				Full	Mini	A4	A3	Swing	Twist Full	Drop Full	Flip Full	Run Full	Clay	Clay Swing	Clay Run	NS	Poppers Full	Mini	Plate Round	Square
1	Handgun 1		1		20	100	31.3%	10											4					
2	Handgun 2			1	32	160	50.0%	14											2	4				
3	Handgun 3	1			12	60	18.8%	5												2				
<b>Total HG</b>					64	320	100.0%																	
4	Rifle 1		1		20	100	31.7%		12										2					
5	Rifle 2			1	34	170	54.0%		16										2				2	
6	Rifle 3	1			9	45	14.3%		4										1				1	
<b>Total Rifle</b>					63	315	100.0%																	
7	Shotgun 1			1	28	140	53.8%																28	
8	Shotgun 2		1		16	80	30.8%												2				16	
9	Shotgun 3	1			8	40	15.4%																8	
<b>Total SG</b>					52	260	100.0%																	
<b>Total Match</b>		3	3	3	306	635	100%	29	32	0	0	0	0	0	0	0	0	0	0	13	6	0	52	3

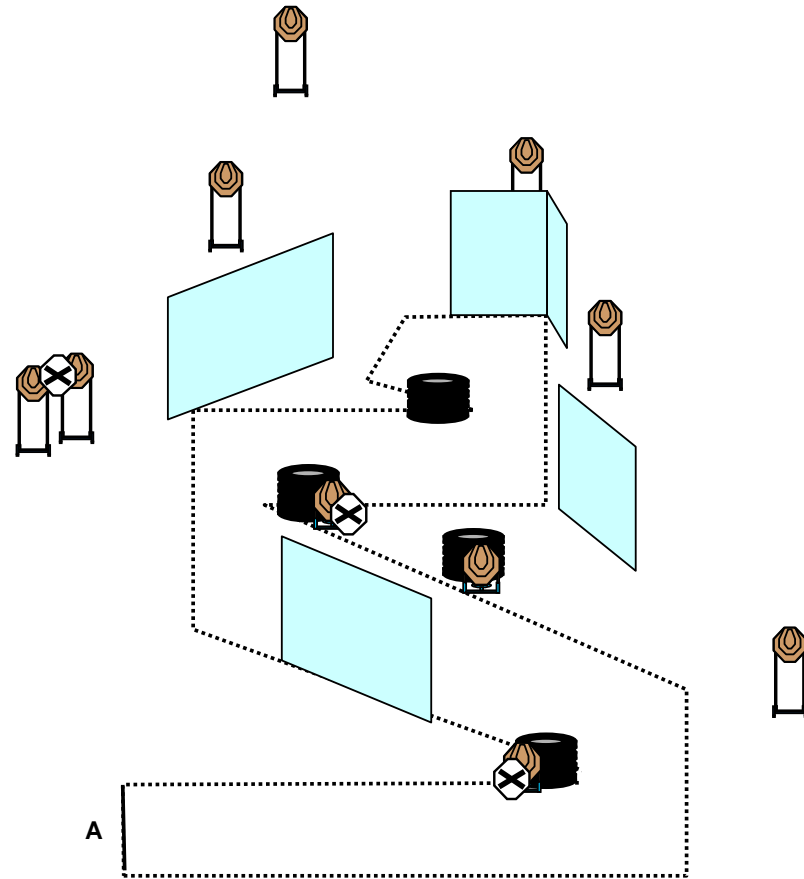

Stage Name - On your mark!!

Stage 1

Start position: Standing one heel touching A, handgun loaded and holstered.

Stage procedure:

Rounds - 20  
Points - 100  
Targets - 10 classic targets  
Distances - 10 - 15m

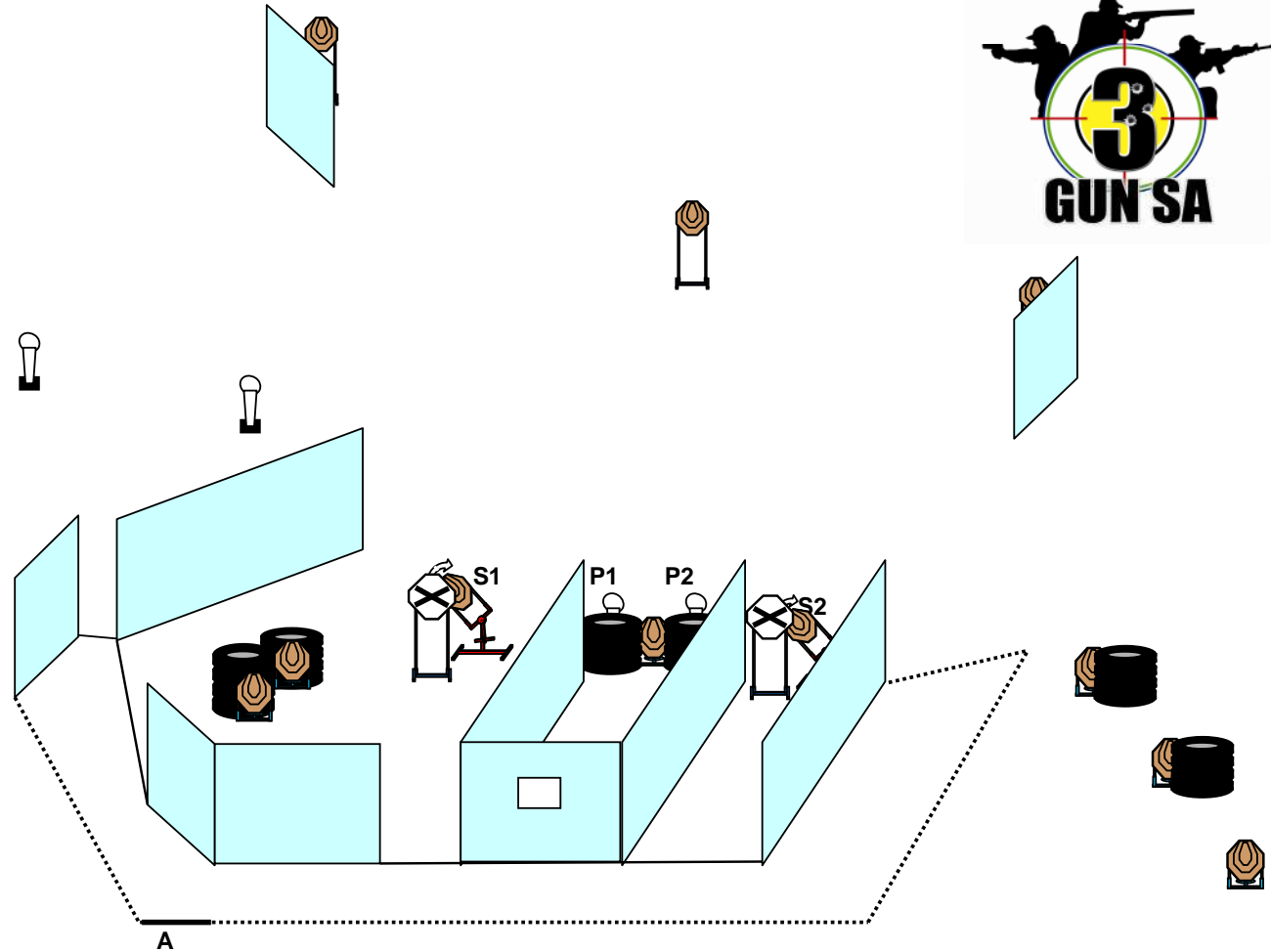

Stage Name - It's complicated

Stage 2

Start position: Standing with both heels touching A, handgun is loaded and holstered.

Stage procedure: P1 activates swinger 1, P2 activates swinger 2. Both remain visible. **Poppers must be activated before engaging the swingers.**

Rounds - 32

Points - 160

Targets - 4 poppers, 14 classic targets

Distances - 10 - 20m

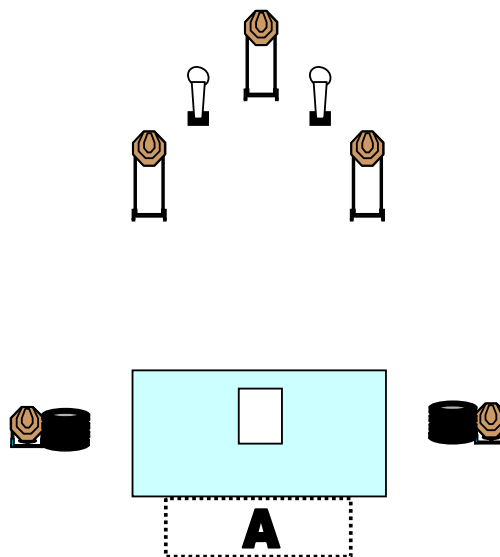

Stage Name - Go for it!	Stage 3
Start position: Standing anywhere in area A, handgun is unloaded and holstered, all magazines on belt.	
Stage procedure:	Rounds - 12 Points - 60 Targets - 2 poppers, 5 classic targets Distances - 10 - 15m

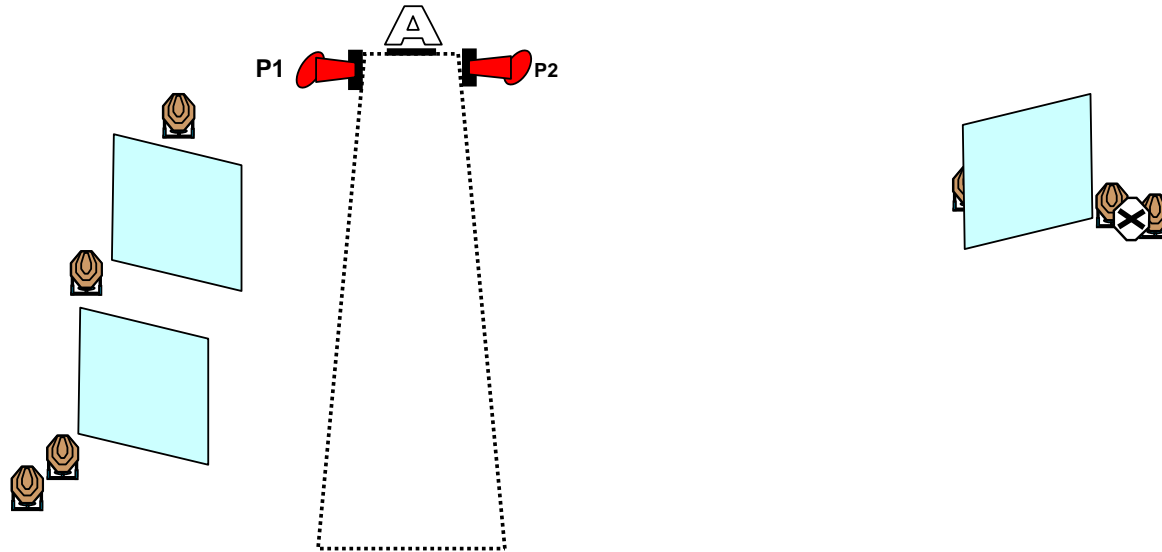
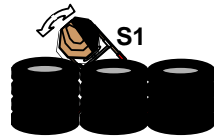

### Stage Name - Let Rip!!!!

### Stage 1

Start position: Standing at A, both feet touching the brandering. Rifle loaded option 1

Stage procedure: P1 activates swinger 1 , P2 activates swinger 3. **P1 and P2 must only be activated by the shooter using any part of their body. The Rifle may not be used and the poppers may not be shot.** The COF will require all paper targets to be engaged with a minimum of two shots each.

Rounds - 20  
 Points - 120  
 Targets - 12 classic mini targets, 2 N/S poppers  
 Distances - 10 - 25m

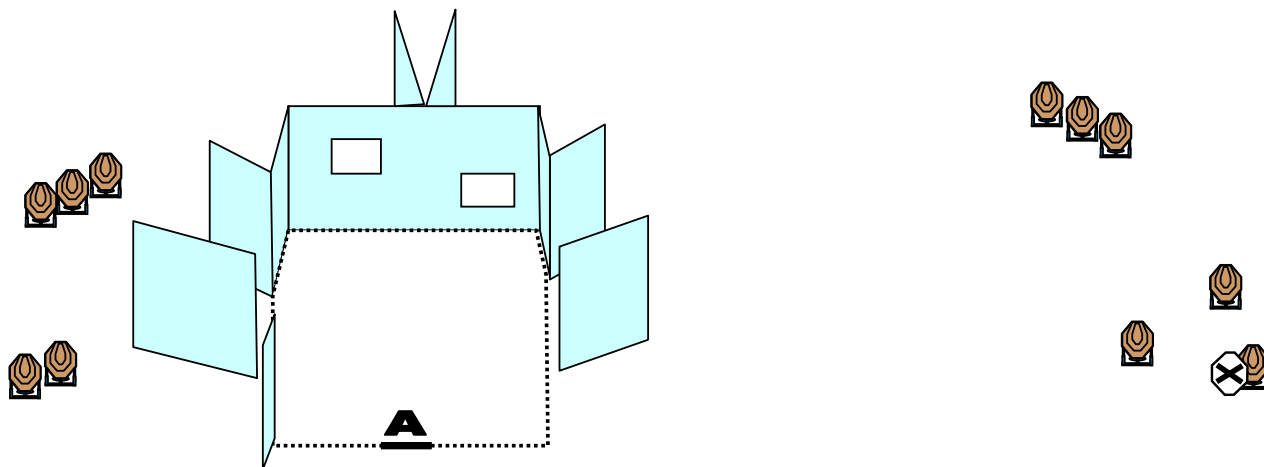

Stage Name - Too much fun!!	Stage 2
Start position: Standing with one heel touching A, rifle loaded option 2	
Stage procedure: Best two shots on paper targets to score, steel must be down to score.	Rounds - 34 Points - 175 Targets - 2 plates, 16 mini targets, 2 N/S Distances - 10 - 50m

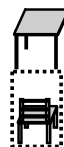

Stage Name - Quickie!!

Stage 3

Start position: Sitting on chair, back against, rifle placed on table loaded option 1.

Stage procedure:

Rounds - 9

Points - 45

Targets - 1 plates, 4 classic mini targets

Distances - 10 - 65m



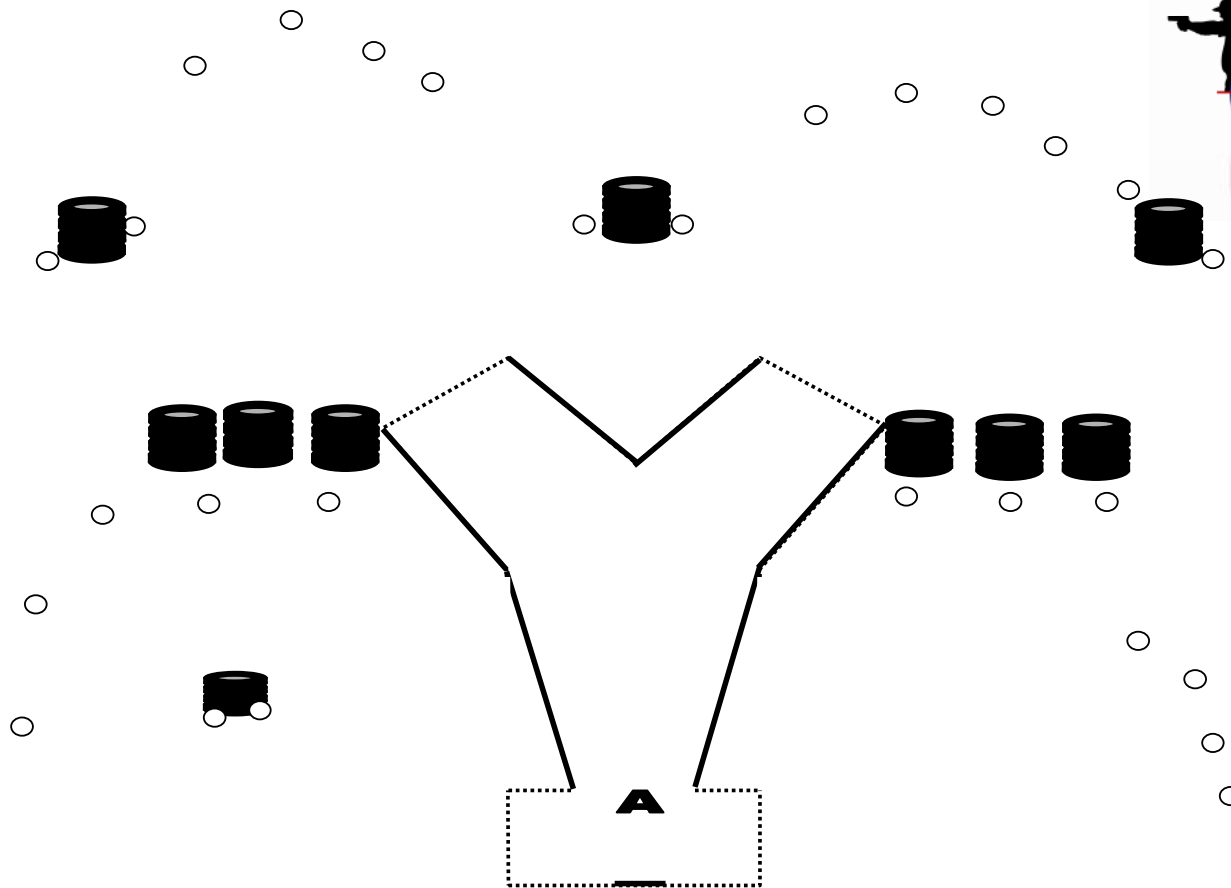

Stage Name - Carlo!!	Stage 2
Start position: Standing with one heel touching A, shotgun loaded option 1	
Stage procedure:	Rounds - 28 Points - 140 Targets - 28 plates Distances - 10 - 20m

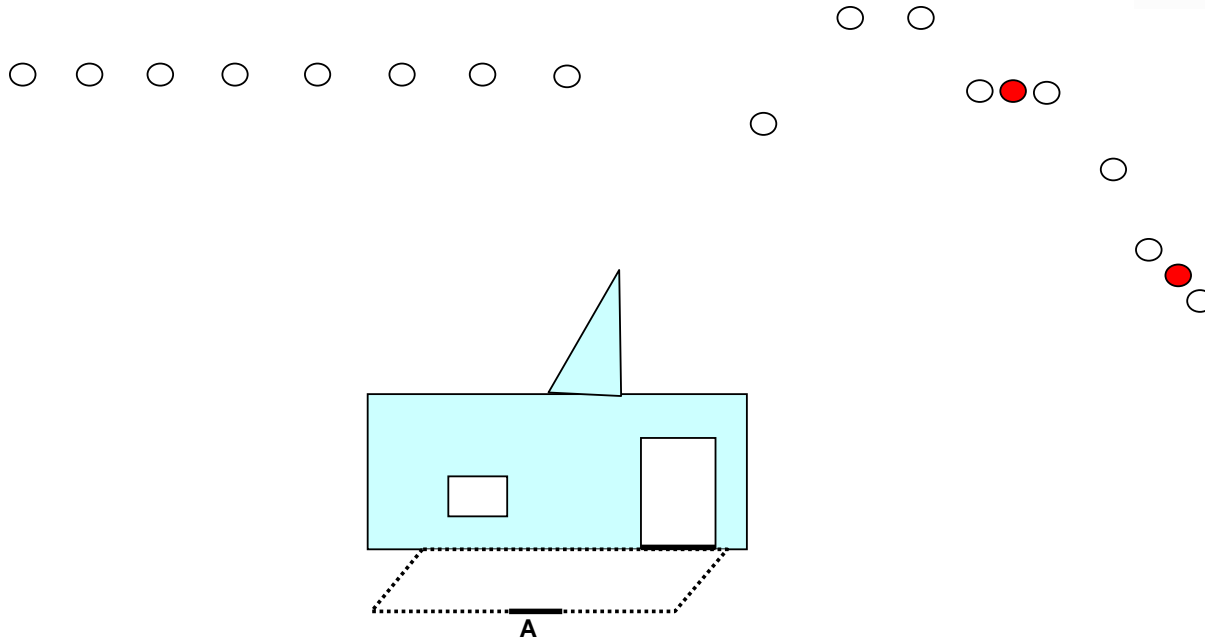

Stage Name - Tito	Stage 2
Start position: Standing with one heel touching A, shotgun loaded option 1	
Stage procedure:	Rounds - 16 Points - 80 Targets - 16 plates, 2 N/S plates Distances - 10 - 15m

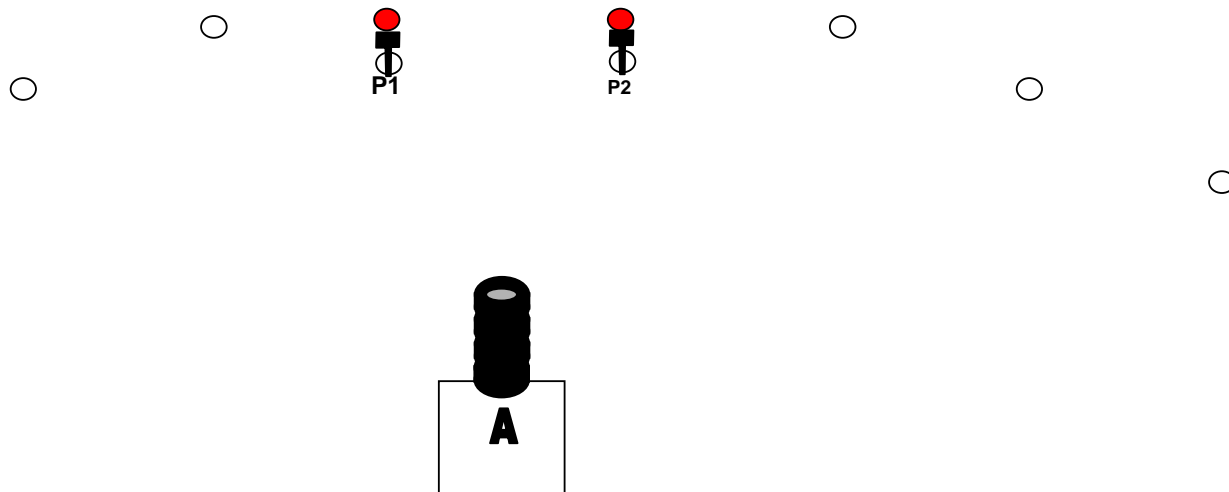

Stage Name - Mario	Stage 3
Start position: Standing in box A, weak hand touching tyres, shotgun held in strong hand parallel to the ground, shotgun loaded option 2	
Stage procedure: P1 and P2 can be shot under the N/S plates. N/S plates only score a penalty if there is at least one pellet mark on it. If there is/are no pellet mark/s on it, it doesn't score because it was not hit directly but rather the base was. N/S plates have to be painted after every hit.	Rounds - 8 Points - 40 Targets - 8 plates, 2 N/S plates Distances - 10 - 15m